

MESA BISTRÔ

BISTRÔ TABLE

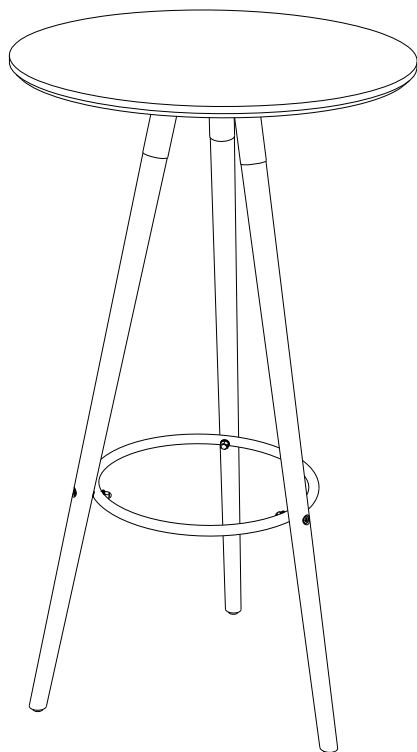

Seat&Co

INDÚSTRIA DE MÓVEIS

Utilizar a régua abaixo para medir os componentes.
Use the ruler below to measure the components.
Usa la regla de abajo para medir los componentes.

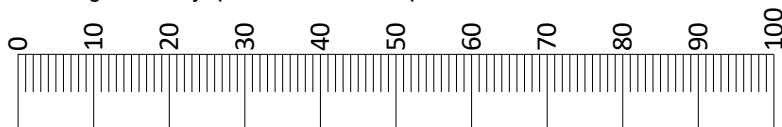

medidas em mm
measurements in mm
medidas en mm

Composição do Produto

Product Composition

Composición del Producto



1 Tampo (1x)
Table (1x)
Superior (1x)



2 Suporte (1x)
Bracket (1x)
Reposapiés (1X)



3 Pés (3x)
Legs (3x)
Patás (3x)



4 Aro (1x)
Ring (1x)

Componentes de Montagem

Assembly Components

Composición del Producto



A- Parafuso allen
Allen screw
Tornillo Allen
M6x50 (3x)

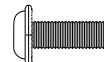

B- Parafuso allen
Allen screw
Tornillo Allen
M6x16 (3x)

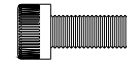

C- Parafuso allen
Allen screw
Tornillo Allen
M10x25 (3x)



D- Arruela lisa
Flat washer
Arandela plana
M6 (3x)



E- Arruela lisa
Flat washer
Arandela plana
M10 (3x)



F- Porca sextavada
Hex nut
Tuerca hexagonal
M6 (3x)



G- Arruela de Pressão
Pressure Washer
Arandela de presión
M6 (6x)



H- Chave "L" Hexagonal
Hexagonal "L" Key
Llave "L" Hexagonal
M6 (1x)



I- Chave "L" Hexagonal
Hexagonal "L" Key
Llave "L" Hexagonal
M10 (1x)



J- Porca sextavada
Hex nut
Tuerca hexagonal
M6 (1x)

Recomendações:

- 1 - Leia atentamente toda a instrução antes de iniciar a montagem.
- 2 - A montagem do produto deverá ser feita em uma superfície limpa e plana. Aconselhamos utilizar a própria embalagem para forrar o chão a fim de não danificar o produto.
- 3 - Reservar área livre para montagem do produto.
- 4 - Não sentar-se ou subir na mesa.

Recommendations:

- 1- Read the entire instruction carefully before starting the assembly.
- 2- The product must be mounted on a clean and flat surface. We recommend using the packaging itself to cover the floor in order not to damage the product.
- 3- Reserve a free area for product assembly
- 4 - Do not sit or climb on the table.

Recomendaciones:

1. Lea atentamente toda la instrucción antes de iniciar el montaje.
2. El montaje del producto deberá ser hecho en una superficie limpia y plana. Aconsejamos utilizar el propio embalaje para cubrir el piso a fin de no dañar el producto.
3. Reservar una área libre para el montaje del producto.
4. No se sienta ni se suba a la mesa.



Pessoas necessárias para montar o produto
People needed to assemble the product
Personas necesarias para montar el producto



Tempo de montagem aproximado
Approximate assembly time
Tiempo aproximado de montaje



Grau de dificuldade
Difficulty level
Nivel de dificultad



-Não utilizar químicos ou abrasivos na limpeza, evitar batidas e contato com objetos cortantes.
-Do not use chemicals or abrasives for cleaning, avoid knocks and contact with sharp objects.
-No utilice químicos ni abrasivos para la limpieza, evite los golpes y contacto con objetos afilados.



-Pano umedecido com água seguido de pano seco.
-Cloth moistened with water followed by dry cloth
-Paño humedecido con agua seguido de paño seco.



-Capacidade máxima suportável, distribuída uniformemente.
-Maximum bearable capacity, evenly distributed.
-Maxima capacidad soportable, distribuída uniformemente.

1 Montagem Assembly Montaje

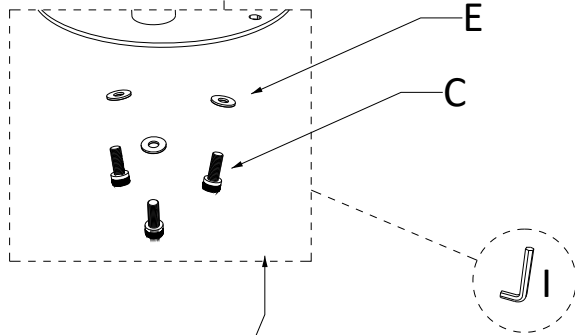
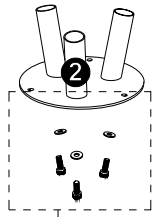
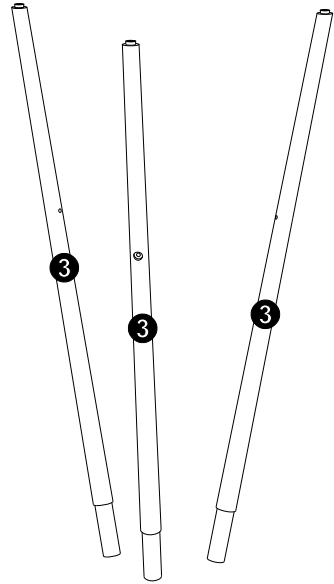

-Para garantir o assentamento da estrutura, não apertar totalmente os parafusos.
-To ensure the structure is settled, do not fully tighten the screws.
-Para asegurarse de que la estructura esté asentada, no apriete completamente los tornillos.

2



-Encaixar peça (4) na base de madeira após fixação de todos os parafusos de travamento do suporte.
-Fit part (4) to the wooden base after fixing all the support locking screws.
-Montar la pieza (4) en la base de madera después de fijar todos los tornillos de bloqueo del soporte.

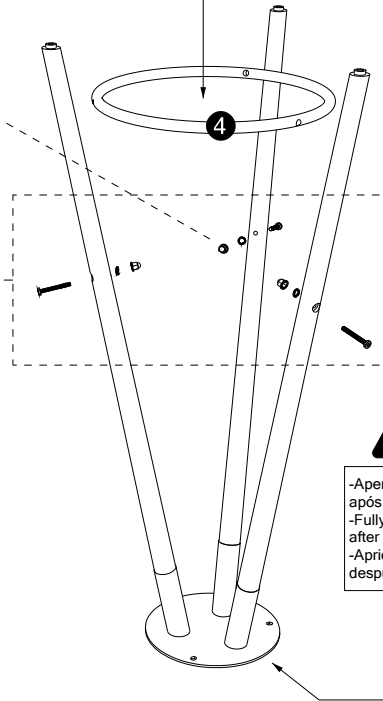
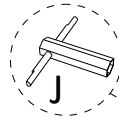

-Apertar totalmente os parafusos item (C), após encaixe da peça (4).
-Fully tighten the screws item (C), after fitting part (4).
-Apriete completamente los tornillos item (C), después de montar la pieza (4).

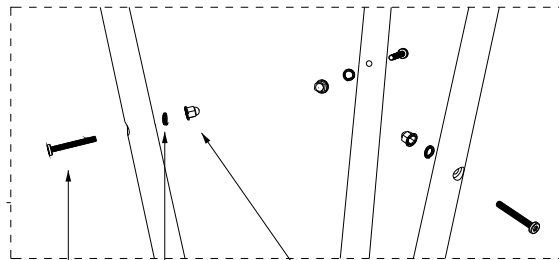

A

G

F



-Deixar alinhado os furos da peça (4) com os furos da peça (3) para fazer a montagem e apertar dos parafusos.
-Alling the holes of the part (4) aligned with the holes in the part (3) to assemble and tighten the screws.
-Dejar los agujeros de la pieza (4) alineados con los agujeros de la pieza (3) para montar y apretar los tornillos.

3

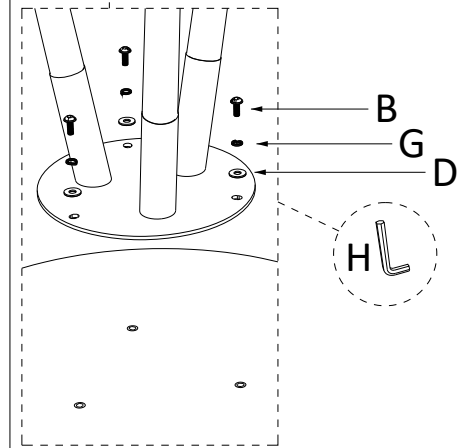
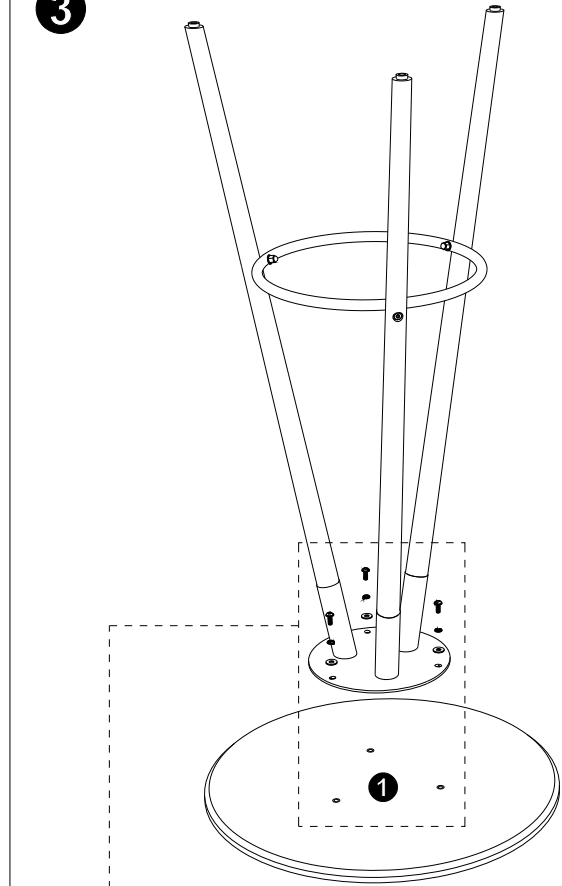

Seat&Co

INDÚSTRIA DE MÓVEIS